

Trevoli BJZ Series

Part No.	hp	kW	Inlet/Outlet	Phase	Voltage	Bare Pump	Mechanical Controller	DSK Controller	Watertech Controller
BJZ037	0.5	0.37	25mm	1	220-240	\$340	\$414	\$414	\$484
BJZ100	1	0.75	25mm	1	220-240	\$400	\$474	\$474	\$544
BJZ150	1.3	1.00	25mm	1	220-240	\$494	\$566	\$566	\$636



BJZ 037



BJZ 100



BJZ 150

DESCRIPTION

The BJZ series with their proven reliability and excellent self-priming ability make them ideal for any house or farm water supply system. The Jet and venturi design allows suction lift up to 8m – great for drawing from rivers, dams & ponds, shallow wells and underground tanks. Easy to prime.

TECHNICAL FEATURES

- Max working pressure: 6bar
- Max liquid temperature: +60c
- Max suction lift: 8m

MOTOR FEATURES

- TEFC continuous duty motor
- Class B Insulation
- Ambient temperature range: -15 to +40oc
- Internal overload protector
- IP55 protection

CONSTRUCTION MATERIALS

- Pump casing, Seal plate , pump shaft & Impeller: 304 Stainless steel
- Mechanical seal: Carbon/Ceramic
- Diffuser/Venturi: PPO
- O Rings: EPDM
- Motor mount and casing: Aluminium

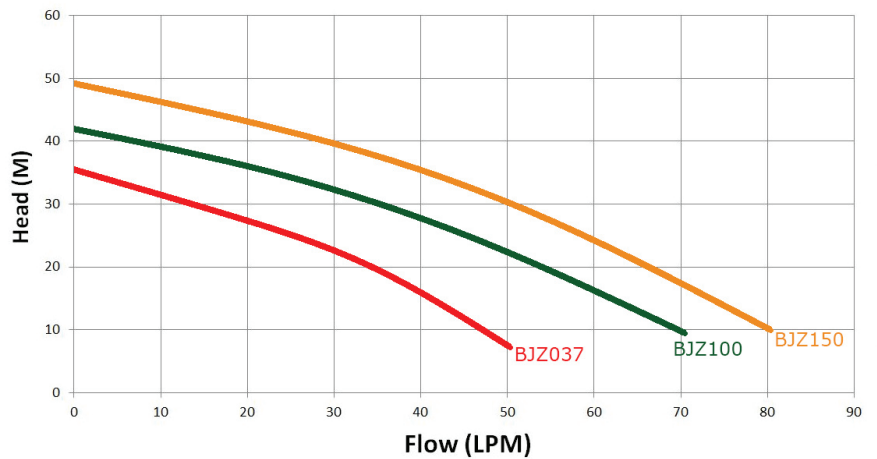

Overall dimensions

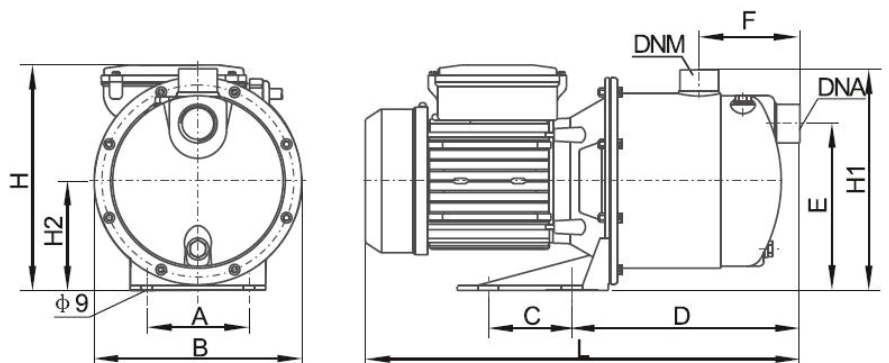

Model	A	B	C	D	E	F	L	H	H1	H2
BJZ037	100	170	N/A	197	128	88	365	182	178	88
BJZ100	98	184	N/A	160	148	80	354	206	202	98
BJZ150	98	198	80	219	160	97	417	216	212	105