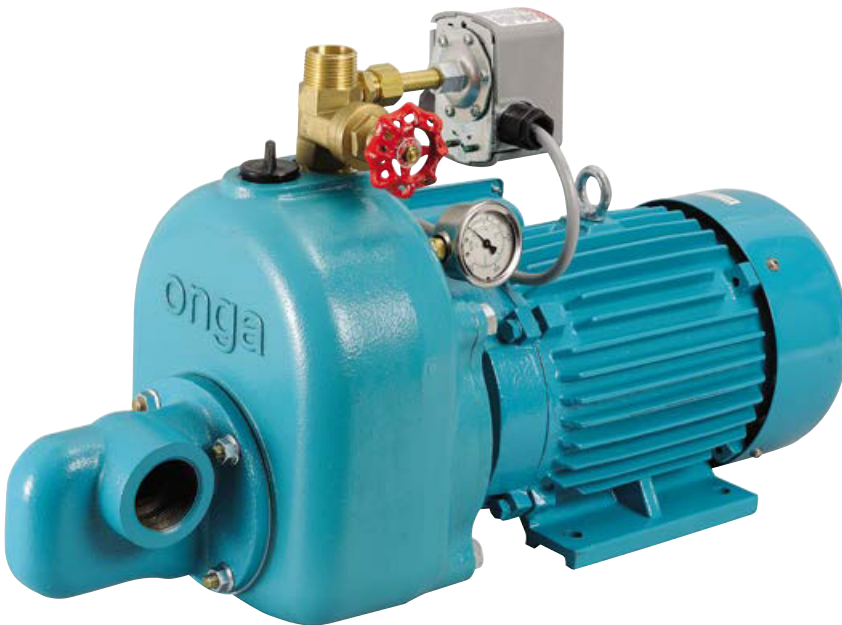

ONGA®

OJ800

ONGA JET FARMMASTER PUMP JET ASSISTED PRESSURE PUMP

OJ800

FEATURES

Injectors to suit large range of applications.

Offset combinations available.

No moving parts down bore.

Shallow well lifts to 7.6m.

Deep well lifts to 49m.

Manual or automatic system.

Max. head - 123m.

Max. flow - 255lpm.

APPLICATIONS

-Domestic, industrial or rural pressure pump for use as a manual or an automatic pressure system.

-Stock watering, irrigation and water transfer.

-Option of a large range of water sources including tanks, bores, dams, creeks and rivers thanks to various injector combinations.

PUMP INFORMATION

Horizontal, single-stage, surface mounted centrifugal pump. Jet and venturi assisted performance with closed impeller for pumping debris free water. Cast iron injector housing and pump casing with 1½" BSP (female) inlet and 1" BSP (female) outlet.

OPERATING CONDITIONS

Suitable for pumping clean non-aggressive liquids without solids or fibres in suspension.

Fluid:	Water.
Maximum water temperature:	55°C.
Minimum water temperature:	1°C.
Maximum ambient temperature:	40°C.

SCOPE OF SUPPLY

OJ800 pump and motor.
Pressure switch fitted.
Pressure gauge.

ELECTRICAL DATA

Type	Type of current	Voltage ± 10%	Frequency Hz	Motor rating kW		Nominal RPM	Current Ampere	Locked rotor current	Motor protection	Insulation class	IP rating	Power supply lead
				P1	P2							
OJ800	1-phase	230/460	50	3.6	2.4	2900	14/7	76	Auto	B	44	15 A
OJ800	3-phase	400	50	3.4	2.4	2900	5.7	48	-	B	44	-

PERFORMANCE

Type	Injector model	Pressure switch setting (kPa)	Suction depth (m)	Total head in metres												Max. pump pressure (kPa)					
				15	21	27	34	40	46	52	58	64	70	76	82		88	95			
				Capacity (litres per minute)																	
OJ800	S800	210-350#	0	245	241	218	156	72											430		
			3	196	193	174	125													400	
			6	140	137	124	89														370
			7.6	65	64	55	32														355
	S801	280-455*	0		215	204	160	116	66											525	
			3		172	163	128	93	53											495	
			6		123	116	91	66												465	
			7.6		86	82	64	46												450	
	S802	350-560*	0				154	150	117	85	54	25								635	
			3				123	120	94	68	43	20								605	
			6				88	86	67	48	31									575	
			7.6				62	60	47	34	22									560	
	S803	420-630*	0					112	88	64	42	25								730	
			3					90	70	51	34	20								700	
			6					64	50	36	24	14								670	
			7.6					45	35	26	17	10								655	
	S804	490-700*+	0						90	67	47	31	18							800	
			3						72	54	38	24	14							770	
			6						51	38	27	18	10							740	
			7.6						36	27	19	12	7							725	
	S805	630-840*+	0							70	57	43	31	21						970	
			3							56	46	34	25	17						880	
			6							40	32	25	18	12						850	
			7.6							28	23	17	12	8						835	
S806	770-1050*+	0										34	33	30	25	18			1145		
		3										27	26	24	20	14			1115		
		6										19	18	17	14	10			1085		
		7.6										14	13	12	10	7			1070		

#Factory pressure switch setting. *Pressure switch adjustment needed. +700248 pressure switch required.

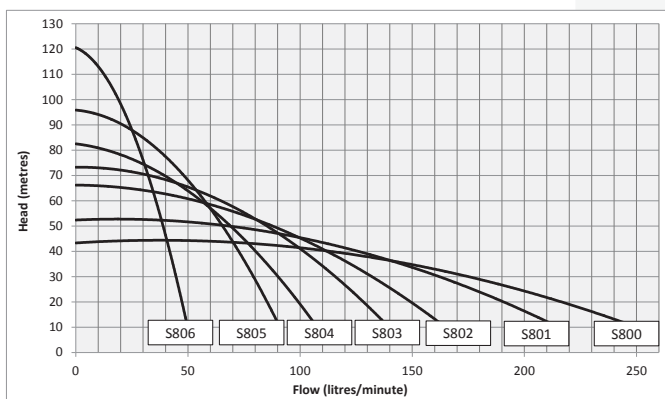

DIMENSIONS

Type	Maximum L x W x H	Weight approx.	Inlet	Pump outlet	Pressure kit outlet	Carton L x W x H	Packed weight
OJ800/1	640 x 220 x 350 mm	50 kg	1½" BSP (female)	1" BSP (female)	1" BSP (female)	670 x 480 x 470 mm	58 kg
OJ800/3	645 x 280 x 350 mm	50 kg	1½" BSP (female)	1" BSP (female)	1" BSP (female)	670 x 480 x 470 mm	58 kg

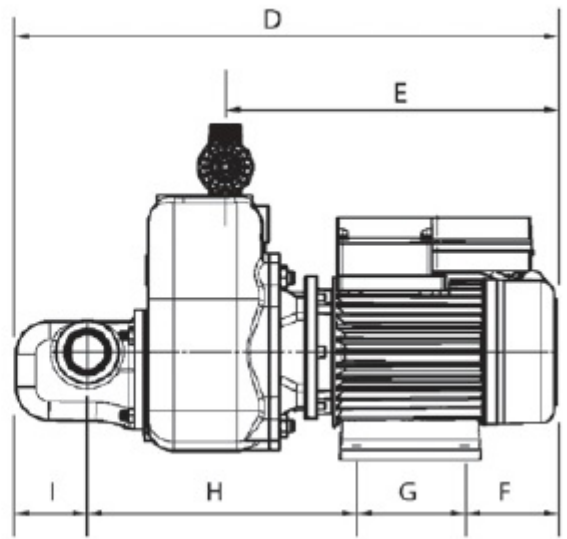
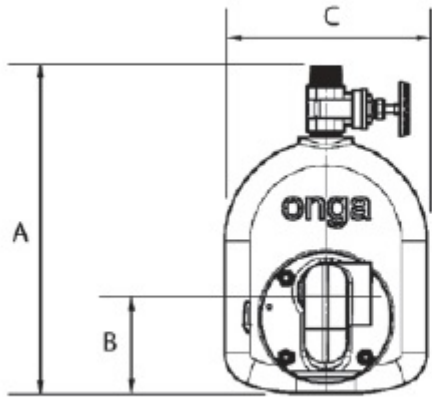

Type	A	B	C	D	E	F	G	H	I
OJ800/1	350	110	280	640	410	120	140	300	80
OJ800/3	350	110	280	640	420	125	140	300	80

MATERIALS OF CONSTRUCTION

Component	Material
Pump casing	Cast iron
Casing spigot	-
Baffle	Noryl
Priming/drain plug	Acetal
Impeller	Polycarb 20% Glass Filled
Diffuser	Noryl
Shaft sleeve	Stainless Steel
Seal flexible bellows	Elastomer EPDM
Seal stationary face	Ceramic
Seal rotating face	Resin Impregnated Carbon Graphite
Seal spring	304 Stainless Steel
Motor shaft	Mild Steel
O'Rings	Nitrile