

HSA500/ HSA750 Exploded View

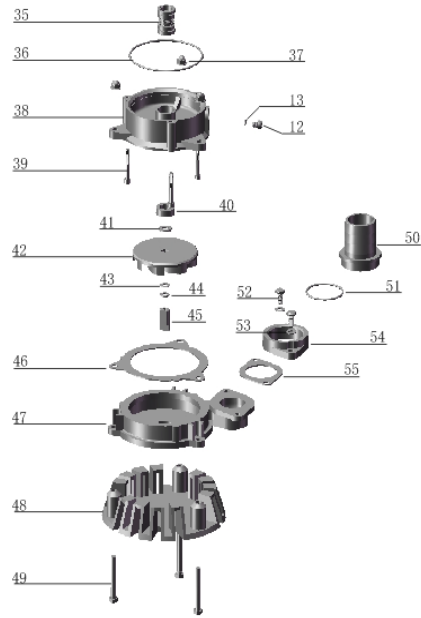
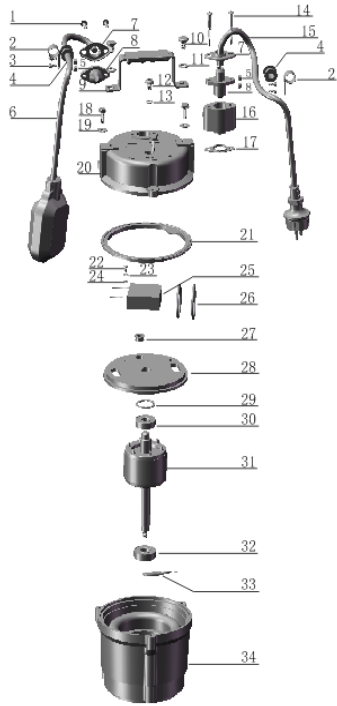

No	Description	Material	No	Description	Material
1	Screw	201	30	Upper bearing	
2	Cable presser	304	31	Rotor	
3	Screw	201	32	Lower bearing	
4	Protector	NR	33	Motor protector	
5	Nut	201	34	Motor casing	AlSi12
6	Float switch		35	Mechanical seal	CA/CE
7	Flange	304	36	O ring	NBR
8	Cable protector	CR	37	Nut	201
9	Handle	Stainless Steel	38	Connection part	200
10	Bolt	201	39	Screw	201
11	Washer	201	40	Oil seal	
12	Screw	201	41	Washer	201
13	O ring	NBR	42	Impeller	NBR(Stainless inserted)
14	Screw	201	43	Washer	201
15	Cable		44	Spring washer	201
16	Tee	Pa66	45	Agitator	Steel
17	Gasket	NBR	46	Gasket	NBR
18	Bolt	201	47	Pump body	200
19	Washer	201	48	Base plate	NBR
20	Capacitor cover	AlSi12	49	Bolt	201
21	Gasket	NBR	50	Connector	ABS
22	Screw	CuZn40	51	O ring	NBR
23	Washer	CuZn40	52	Bolt	201
24	Serrated washer	201	53	Washer	201
25	Capacitor		54	Connection nut	200
26	O ring	NBR	55	Gasket	NBR
27	Line protector	NBR			
28	Motor cover	AlSi12			
29	Undulated washer	1566			