



DCX SERIES

High Pressure Submersible Pump

The DCX series are a high pressure submersible pump most commonly used in treated effluent disposal applications. Featuring a large single impeller with high passage clearance up to 5mm to avoid blockages, Double mechanical seal for long term durability, rugged cast iron construction.

Features:

- Cast iron pump housing and motor top cover
- 304 Stainless steel motor housing
- Glass fiber reinforced impeller
- Double sided mechanical seal in oil bath: Silicon carbide/silicon carbide - pump side
Carbon/Silicon carbide – Motor side
- Maximum liquid temperature: 40°C – continuous rated
- Class B rated motor insulation
- Incorporated motor thermal protector
- 10m Lead length
- Complete with Float switch supplied as standard

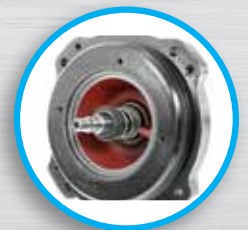

DCX SERIES						
Part No.	HP	kW	Ph	Amps	Volts	Float Switch
240-DCX500A	0.5	0.37	1	3.7	230	Yes
240-DCX1000A	1.0	0.75	1	5.3	230	Yes
240-DCX1500A	1.5	1.1	1	7.1	230	Yes

Performance:

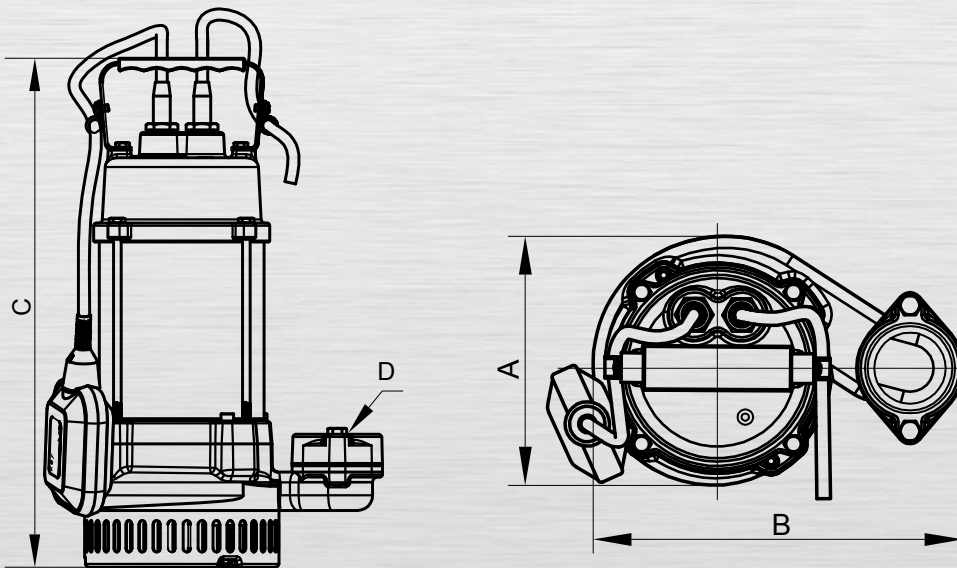
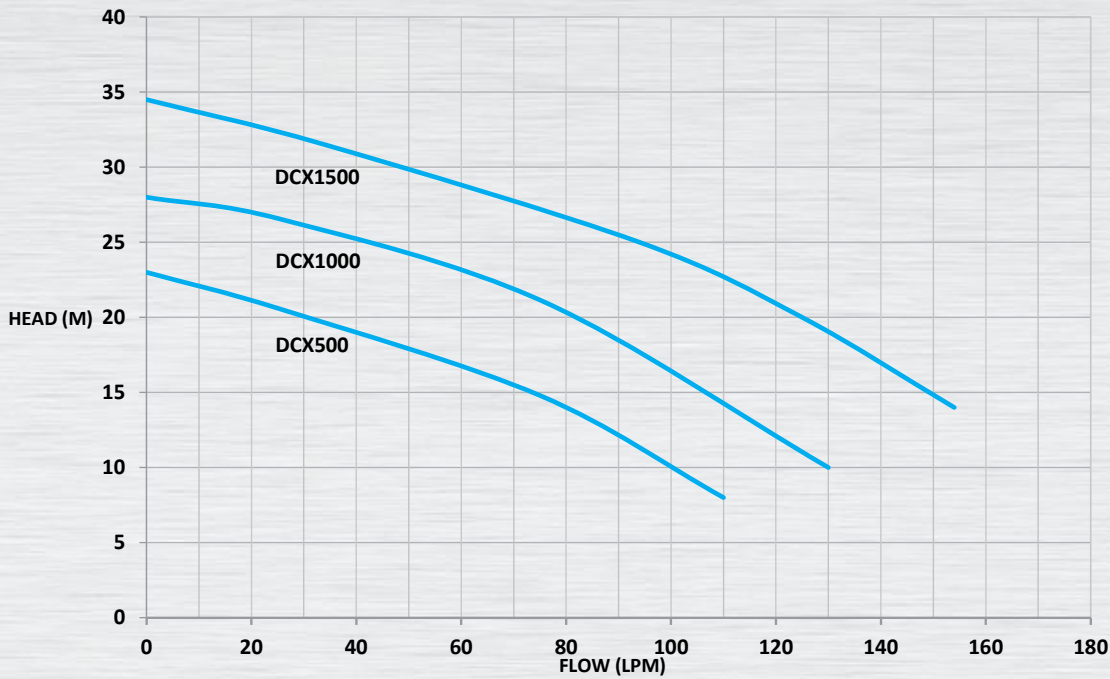

DIMENSIONS & SPECIFICATIONS					
Part No.	A	B	C	D	Kg
DCX500A	185	260	420	1"	19
DCX1000A	185	260	420	1"	20
DCX1500A	185	260	420	1"	21