



Submersible Pump

BIA-B10A
BIA-B15A
BIA-B25A
BIA-B40A
BIA-B42A
BIA-B15VA
BIA-B25VA
BIA-B40VA
BIA-B75A
BIA-B75VA
BIA-B75KA
BIA-B120G



Installation & Operating Instructions

BIANCO B range of submersible pumps is suitable for small to medium dewatering and or wastewater applications. The Vortex pumps (VA) are able to pump soft solids in suspension. The KA cutter pump has a impeller with an edged tungsten tip and a grinding plate to assist with cutting of fibrous materials.

The G grinder pump consists of a high chrome impeller and grinder which can grind soft solid materials in sewage.

Dewatering Pumps: B10A, B15A, B25A, B40A, B42A, B75A

Vortex Pumps: B15VA, B25VA, B40VA, B75VA

Cutter Pump: B75KA

Grinder: B120G

Voltage: 240V 50Hz Single Phase

Submersible pumps are very quiet and are ideal for applications within residential areas for storm water pits, basements, etc

Suitable Fluids

The Cutter (K) models are suitable for pumping soft solids in suspension. The Cutter and Grinder (G) pumps are also suited to pump soft string-like materials such as hair, lint, straw etc. Grinder models can pump cloth, rubber gloves, etc. The cutter and grinder pumps should not pump hard solids as these will damage the pump face.

Pumps are **not to be used** for pumping flammable or corrosive fluids.

Installation

The BIANCO B series pumps are completely submersible up to 10 metres and can be installed on a level surface in a stationary position connected to either fixed pipe work or flexible hose. Never remove or lift a pump by the power cable. Instead connect a rope to the handle during installation.

External float switch versions should be placed in a sump of a suitable size so that the float switch is not restricted or could be caught in the up position. The float switch must be installed so that the ON and OFF operating points can be easily reached, and that the float switch head is not too close to the latching holder which prevents correct operation. The float switch must not touch the base of the sump or tank which will prevent the pump turning off.

All pumps must not be allowed to run dry.

Motor Cooling

All models rely upon water flow around the motor for correct motor cooling.

All models are suitable to operate partially submerged for periods up to 10 minutes.

Operating at very low flows caused by high heads or restricted pipe work may cause motor over heating.

Power Connection

A power point (10 amp) should be provided by a qualified electrician, and a residual current device with a nominal trip current should be installed in compliance with the requirements of AS 3000.

All single phase models have an automatic reset thermal overload protection built in, and overload will switch the motor off and later will automatically reset and switch the motor on when the motor has cooled down.

The appliance (pump) is not intended for use by young children or infirm persons without supervision

Young children should be supervised to ensure that they do not play with the appliance.

If the supply cord is damaged, the pump should be returned to White International or one of its Service Agents for repair in order to avoid a hazard.

Trouble Shooting

Fault	Cause	Remedy
Pump does not start	No mains supply	Check that power is available and switch is on
	Blown fuse or tripped breaker	Replace or reset
	Impeller jammed	Disconnect power and clean impeller area
	Pump has turned off on thermal cut out	Allow time to reset
	Float switch jammed down	Free switch and move pump
	Insufficient water level	Float switch must be 45 deg above horizontal
No or low flow	Strainer or impeller blocked by debris	Clean strainer and impeller
	Airlock in discharge pipework	Ensure pump body is filled with water
	Discharge hose is bent or kinked	Straighten discharge hose
	Damage caused by dirty or abrasive water	Clean pump and replace parts
	Excessive friction loss or delivery head	Increase pipe size and increase pump size.
Pump will not turn off	Float switch jammed up	Free switch and move pump
	Excessive friction loss or delivery head	Increase pipe size and increase pump size.
Pump switches off after short period	Thermal overload has tripped	Ensure impeller is not clogged Ensure water temperature is below 35 deg C Ensure pump not operating on extension lead Ensure pump not operating at low flow

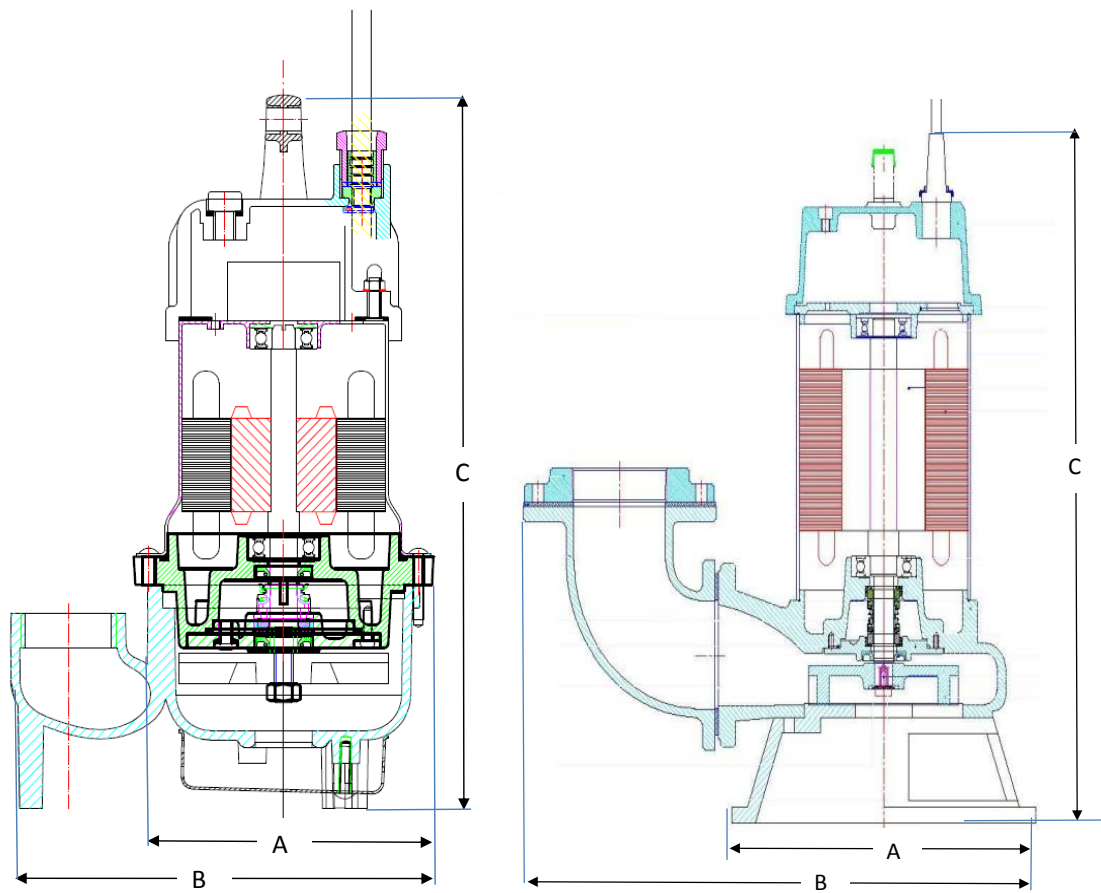

Model	Dimensions (mm)		
	A	B	C
BIA-B10A	132	186	304
BIA-B15A	132	186	304
BIA-B25A	131	196	314
BIA-B40A	143	224	350
BIA-B75A	173	289	488
BIA-B15VA	132	186	304
BIA-B25VA	131	196	314
BIA-B40VA	143	224	350
BIA-B75VA	155	260	435
BIA-B75KA	195	280	420
BIA-B120G	198	237	540

BIA-B42A Dimensions

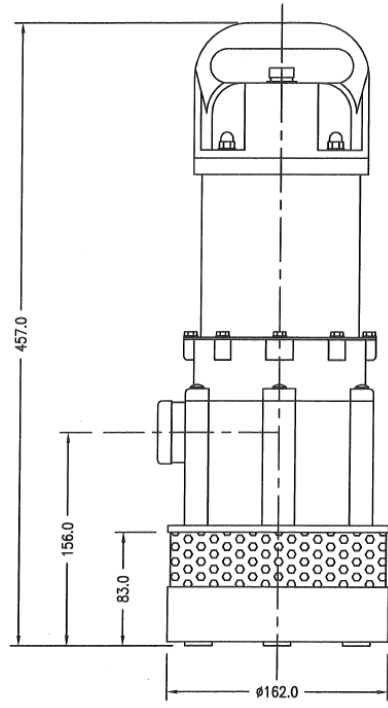



2 YEAR WARRANTY

Terms & Conditions

White International Pty Ltd
Limited Product Warranties
TERMS & CONDITIONS

This warranty is given in addition to the consumer guarantees found within the Australian Competition and Consumer Act 2010 (Cth) for goods purchased in Australia and the Consumer Guarantees Act 1993 NZ for goods purchased in New Zealand:

- 1) White International Pty Ltd / White International NZ Ltd (White International) warrant that all products distributed are free from defects in workmanship and materials, for their provided warranty period as indicated on the top or opposite side of this document. Subject to the conditions of the warranty, White International will repair any defective products free of charge at the premises of our authorised service agents throughout Australia and New Zealand if a defect in the product appears during the warranty period. If you believe that you have purchased a defective product and wish to make a claim under this warranty, contact us on our Sales Hotline on 1300 783 601, or send your claim to our postal address or fax line below and we will advise you as to how next to proceed. You will be required to supply a copy of your proof of purchase to make a claim under this warranty.
- 2) This warranty excludes transportation costs to and from White International or its appointed service agents and excludes defects due to non-compliance with installation instructions, neglect or misuse, inadequate protection against the elements, low voltage or use or operation for purposes other than those for which they were designed. For further information regarding the suitability of your intended application contact us on our Sales Hotline on 1300 783 601. If you make an invalid claim under this warranty, the original product will be sent back to you unrepai red.
- 3) This warranty refers only to products sold after the 1st January 2012, and is not transferable to another product type and only applies to the original owner, purchaser or end user, and is in addition to the consumer guarantees found within the Competition and Consumer Act 2010 (Cth) for goods purchased in Australia and the Consumer Guarantees Act 1993 (NZ) for goods purchased in New Zealand.
- 4) Our goods come with guarantees that cannot be excluded under the Australian Consumer Law. You are entitled to a replacement or refund for a major failure and for compensation for any other reasonably foreseeable loss or damage. You are also entitled to have the goods repaired or replaced if the goods fail to be of acceptable quality and the failure does not amount to a major failure.

- 5) To the fullest extent permitted by law, White International excludes its liability for all other conditions or warranties which would or might otherwise be implied at law. To the fullest extent permitted by law, White International's liability under this warranty and any other conditions, guarantees or warranties at law that cannot be excluded, including those in the Competition and Consumer Act 2010 (Cth), is expressly limited to:
 - (a) in the case of products, the replacement of the product or the supply of equivalent product, the payment of the cost of replacing the product or of acquiring an equivalent product or the repair of the product or payment of the cost of having the product repaired, is at the discretion of White International or a 3rd party tribunal elected under the Competition and Consumer Act 2010 (Cth) for goods purchased in Australia and the Consumer Guarantees Act 1993 (NZ) for goods purchased in New Zealand; and
- 6) To the fullest extent permitted by law, this warranty supersedes all other warranties attached to the product or its packaging.
- 7) In the case of services, supplying the services again or the payment of the cost of having the services supplied again, is at the discretion of White International or a 3rd party tribunal elected under the Competition and Consumer Act 2010 (Cth) for goods purchased in Australia and the Consumer Guarantees Act 1993 (NZ) for goods purchased in New Zealand.
- 8) Our warranty commences from the date of purchase of the above mentioned pumps. Proof of purchase is required before consideration under warranty is given. Record your date of purchase in the space below and retain this copy for your records.

Date of Purchase Model Purchased



WHITE INTERNATIONAL PTY LTD
 ABN 48 000119380
 52-60 Ashford Ave, MILPERRA NSW 2214
 PO BOX 304, MILPERRA LPO NSW 2214
 Ph: 02 9783 6000 Fax: 02 9783 6001
 Customer Service Hotline: 1300 783 601
 Customer Service Faxline: 02 9783 6003
 EMAIL: Sales Enquiries: info@whiteint.com.au

WHITE INTERNATIONAL NZ LTD
 138 Hugo Johnston Dr PENROSE, AUCKLAND, NZ
 PO BOX 12704, PENROSE, AUCKLAND
 Ph: 09 579 977 Fax: 09 579 7775
 Customer Service Hotline: 0800 509 506
 Customer Service Faxline: 0800 804 344
 EMAIL: General Info Enquiries: sales@whiteint.co.nz